



Maritime &
Coastguard
Agency

MARITIME & COASTGUARD AGENCY

**FISHING VESSEL
STABILITY GUIDANCE**

CONTENTS

GLOSSARY OF TERMS	1
AIMS OF THIS BOOKLET	3
PART 1 – GUIDELINES FOR SKIPPERS AND CREW	4
INTRODUCTION	4
A. RISKS AND RESPONSIBILITIES	5
a. What is risk?	5
b. How do you minimise risk?	5
c. The ALARP Method	5
B. PRINCIPLES	7
a. What is stability?	7
<i>i. Weight</i>	7
<i>ii. Buoyancy</i>	7
b. Centre of gravity	8
c. Centre of buoyancy	9
How can you affect the centres of gravity and buoyancy?	10
a. Affecting the centre of gravity	10
<i>i. Location of weights</i>	10
b. Affecting the centre of buoyancy	11
Buoyancy and the importance of beam	12
a. Vessels with a wide beam	12
b. Vessels with a narrow beam	12
Buoyancy and the importance of freeboard	13
a. Vessels with good freeboard	13
b. Vessels with little freeboard	13
C. SUMMARISED RULES FOR GOOD STABILITY	14
a. Low centre of gravity	14
b. Wide beam	14
c. Good freeboard	14

D. STABILITY HAZARDS AND RISKS	15
a. What are the hazards and risks to stability and how can you minimise them?	16
i. <i>External forces causing a heel</i>	16
ii. <i>Uneven weight distribution causing a list</i>	16
iii. <i>Unexpected movement of weights</i>	17
iv. <i>Movement of liquids in tanks</i>	17
v. <i>Free surface effect</i>	18
vi. <i>Vertical movement of weight</i>	19
vii. <i>Loll</i>	20
viii. <i>Suspended loads</i>	20
b. Preventing a chain of events	23
PART 2 – SKIPPER’S SECTION	24
INTRODUCTION	24
A. HOW STABILITY CHANGES AS THE VESSEL ROLLS	25
B. HOW CHANGING THE CENTRE OF GRAVITY CAN AFFECT THE VESSEL’S STABILITY	27
C. ROLL PERIODS	29
D. THE WOLFSON MARK	30
E. TANKS	32
a. Depth	32
b. Length – in fore and aft directions	32
c. Breadth – across the vessel	33
d. Free Surface Effect	33
F. MODIFICATIONS	34
ANNEX A	35
FV Roll Test Form	35
FV Heel Test Form	36

GLOSSARY OF TERMS

ALARP – Risk assessment method: ‘As Low As Reasonably Practical’.

Beam – The width at the widest point as measured at the **ship’s** nominal waterline.

Buoyancy – The force of the water acting upwards on the hull of the vessel.

Centre of Buoyancy – The average location of the vessel’s buoyancy and should be below the waterline.

Centre of Gravity – the point at which the whole weight of the vessel can be said to act vertically downward, which should be just above the waterline.

Deadweight – Weight of items taken on board for fishing (gear, fuel, oil, water, ice, boxes, provisions, etc.).

Depth – The vertical distance between the waterline and the bottom of the hull (keel), with the thickness of the hull included.

Freeboard – The distance measured vertically downwards from the upper edge of the freeboard deck to the waterline.

Free Surface Effect – The ability of liquids to move freely across a surface. This may be the deck, tanks or holds. Liquids may not be just water but may include fish and other items able to shift freely from one side to another as a vessel heels.

GZ – The horizontal distance between the line of downward force from the weight (acting downward from the centre of gravity) and the buoyancy force (acting upward from the centre of buoyancy).

GZ Curve – The relationship between GZ and the angle of heel.

Heel – When external forces push or pull the vessel from the upright.

Heeling moment – External forces create a heeling moment in two parts: force and distance.

KG – The height of the centre of gravity can be represented by the distance between the keel bottom and the centre of gravity.

Lightweight – Weight of vessel plus fixed equipment.

List – The degree to which a vessel heels (leans or tilts) to either port or starboard. A listing vessel is stable and at equilibrium, but the distribution of weight aboard (often caused by uneven loading or flooding) causes it to heel to one side.

Loll – The state of a vessel which is unstable when in an upright position and therefore floats at an angle to one side. If disturbed by some external force, i.e. wind or waves, the vessel may lurch to the same angle of loll on the opposite side.

Roll period – The time taken to roll from one side, over to the opposite side, and back again.

Slack tank – A tank which is not full, where liquid will flow to one side when a vessel heels and move the centre of gravity with it, creating the potential for capsize.

Stability – A measure of a vessel's ability to get back on an even keel after having suffered a heel.

Stiff – A vessel that rolls with a quick motion because the vessel's buoyancy is pushing back quickly against the roll. This vessel is less at risk of capsize.

Tender – A vessel that rolls with a slow motion because there is a much-reduced ability of the buoyancy to push back against the roll of the vessel. This vessel is at greater risk of capsize.

Watertight structure – A structure that is capable of preventing the ingress of water from any direction through the structure.

Weathertight structure – A structure that, under any sea conditions, does not allow any water to penetrate.

Weight – The combined mass of both lightweight and deadweight.

Wolfson Mark – Indicates how far the vessel can be heeled for any condition of loading, and for different sea states.

AIMS OF THIS BOOKLET

This booklet is intended to help you understand the principles of stability, the associated risks and hazards and what you can do to minimise them.

It is written in two sections. **Part 1** is aimed at everyone, from the crew member to the skipper, the owner and anyone involved in the management and operation of the vessel. It provides simple information on the basics of stability, the risks and hazards and what action you can take to ensure the vessel stays safe.

Part 2 is aimed at skippers and is intended to provide greater detail on the more advanced concepts of stability.

PART 1

GUIDELINES FOR SKIPPERS AND CREW

INTRODUCTION

The stability of your vessel is vital for both your life and your livelihood.

Although rare when compared to other types of accidents, the suddenness of capsizing means the chance of survival is much reduced and, in many instances, none of the crew survive.

Avoiding capsizing is not just a question of whether your vessel has good stability or not, it is also very dependent on how the vessel is operated and the decisions made whilst fishing.

Being aware of the stability characteristics of your vessel and taking decisions based on those characteristics which minimise risks and hazards, will help to ensure your safety.

It is important that you refer to the Glossary of Terms to get a full understanding of the terms used in the booklet.

A. RISKS AND RESPONSIBILITIES

a. What is risk?

Risk has two parts:

- the probability of an accident – how likely is it to happen?
- the consequences of an accident – how severe will it be?

b. How do you minimise risk?

To minimise risk, you need to address both the probability and the consequence. What actions you take will depend on how big the risk is.

Size of risk can be assessed by looking at how likely it is to happen and what the consequence will be.

$$RISK = probability \times consequence.$$

For instance, the need to address something that happens quite regularly, but which has only a slight consequence e.g. a small bruise, is obviously less than addressing the risk of something that may happen less often, but which could lead to a severe consequence, such as the loss of an arm.

If the consequence is severe, you **must** reduce the chances of it happening.

IN ALL CASES, IF THE CONSEQUENCE IS A CAPSIZE WHICH CAN BE FATAL, THE RISK MUST BE MINIMISED.

c. The ALARP Method

Reducing risk can be expensive, the ALARP Method can be used to assess the risk involved in different potential situations. ALARP stands for 'As Low As Reasonably Practical'.

Diagram 1: The ALARP Method

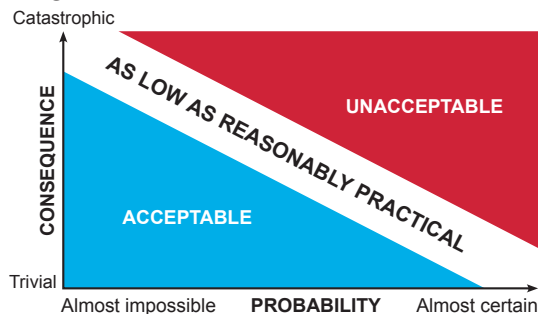

- Risks falling within the top left corner are likely to result in catastrophic consequences but have an almost impossible probability of happening.

- Risks falling within the bottom right corner are trivial items, with a high probability of happening.
- Risks falling within the top right corner are inevitable catastrophic things with a high probability of happening, so you **must** reduce that probability.
- Risks falling in the bottom left corner are trivial things, with an almost impossible probability of happening.

For instance, engine failure may not have a severe consequence, therefore the probability could be left in the middle of the ALARP model, as shown in Diagram 2. A fire would potentially have more severe consequences, as also shown in Diagram 2, so the probability must be reduced into the acceptable section, while the consequences of capsizes would be very severe, so the probability **must** be reduced to almost impossible.

In conclusion, the more probable the accident, and the more severe the consequence, then more that should be done to reduce the probability.

IN ALL CASES, IF THE CONSEQUENCE IS A CAPSIZE WHICH CAN BE FATAL, THE RISK MUST BE MINIMISED.

Skippers must understand:

- the potential hazards of the sea (wind, weather, sea state)
- the necessity to minimise consequence of unexpected sea conditions (water on deck, breaking seas)
- why poorly operated vessels are more likely to get into difficulties
- why well managed vessels are more likely to stay safe.

Diagram 2: Examples of risks using the ALARP Method

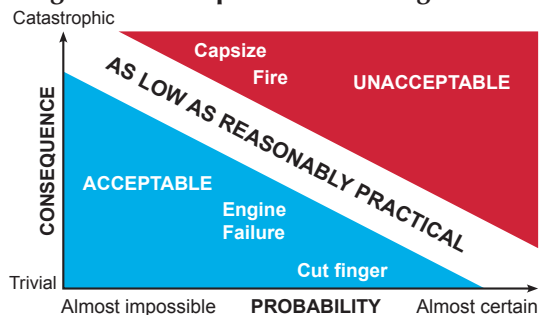

B. PRINCIPLES

a. What is stability?

Stability is a measure of the vessel's ability to get back on an even keel after having suffered a heel. That ability is greatly affected by two forces: the vessel's weight and its buoyancy.

i. *Weight*

The lightweight of your vessel is the vessel itself and any equipment fixed to it.

The deadweight of your vessel is what is taken on board for fishing, such as gear, fuel, oil, water, ice, boxes, provisions, etc.

Weight is the combined mass of both lightweight and deadweight, which both act downwards on your vessel through gravity.

ii. *Buoyancy*

Buoyancy is the force of the water acting upwards.

A vessel is kept upright by the water underneath creating an upward force. The greater the weight downward, the more upward force is needed to counteract it.

Diagram 3: Buoyancy and displacement

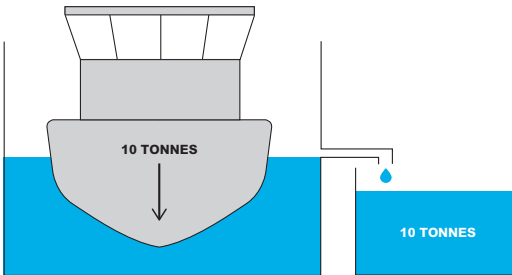

As Diagram 3 above shows, if you have a container full of water and fill it up to the overflow point and then put a vessel weighing 10 tonnes in it, it will force, or “displace”, 10 tonnes of water out through the overflow.

The more of the vessel's surface area that is in contact with the water, the more upward force, or buoyancy there is to help the vessel stay upright.

The vessel's freeboard is the distance from the water surface to the top edge of the deck. Therefore, the more freeboard a vessel has, the more surface area is in contact with the water, giving the vessel more buoyancy and creating a safer vessel.

The following pages explain in greater detail how this works, and how to ensure your weight and buoyancy can be managed to prevent dangerous situations.

b. Centre of gravity

The centre of gravity is the point where mass is pulling down, which in most vessels is just above the waterline.

The location of a vessel's centre of gravity is affected by the construction and layout of the vessel itself, as well as the items of equipment and their position on board.

Diagram 4: The effect of weight and its position

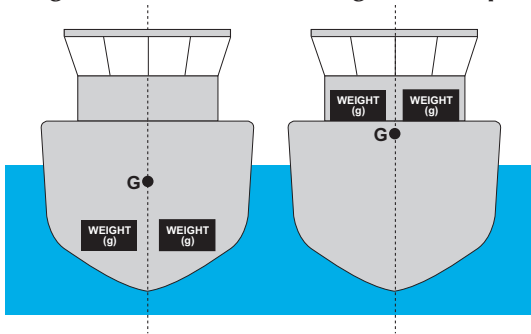

The centre of gravity does not move if the weight does not change or move. Any pitching and rolling of the vessel has no effect on the centre of gravity, which will only alter if weights move or new weight is added.

c. Centre of buoyancy

All the hull that is under the waterline contributes to total buoyancy.

The centre of buoyancy is the average location of the vessel's buoyancy and should be below the waterline.

Diagram 5: The position of the centres of buoyancy and gravity when the vessel is upright

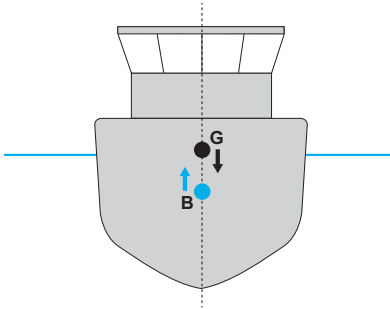

Unlike the centre of gravity, the centre of buoyancy will move depending on the vessel's draft, trim and heel.

As shown in Diagram 6 below, when a vessel heels to one side, the centre of buoyancy also moves across to that side. As the buoyancy is pushing upward, it pushes back against the heel and the downward effect of the vessel's weight, and returns the vessel to an upright position.

Diagram 6: The effect of heel on the centres of buoyancy and gravity

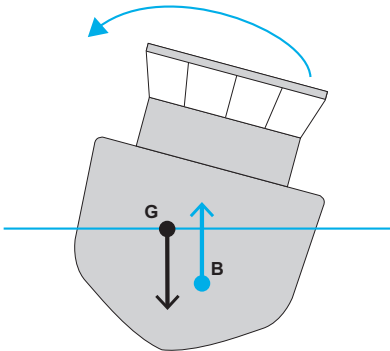

How can you affect the centres of gravity and buoyancy?

a. Affecting the centre of gravity

As previously mentioned, the amount of weight and its position will affect the position of the centre of gravity.

The best position for the centre of gravity is just above the waterline.

i. Location of weights

The centre of gravity will be affected by how high or low you place weight on the vessel. Placing a small weight higher up will have the same effect as a larger weight lower down.

Therefore, if you have added new gantries above the centre of gravity so that the catch is suspended from a point high up, the centre of gravity will be higher. The taller these gantries, the greater the effect on the centre of gravity.

Equally, fitting a lighter engine below the centre of gravity will also raise it higher.

The higher the centre of gravity, the more the vessel is at risk. If the vessel is rolling slowly it is a strong indicator that the centre of gravity is too high, and you need to reduce it.

Diagram 7: The effect on the centre of gravity and its effect on vessel roll

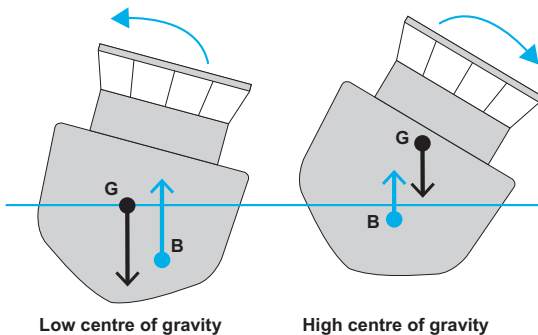

In summary, the centre of gravity will be pulled upward if you do either of the following:

- add more weight above the centre of gravity
- remove weight below the centre of gravity.

b. Affecting the centre of buoyancy

Pitching and rolling both move the centre of buoyancy, which is a natural and essential function for returning the vessel to the upright.

However, there are things you can do to improve the vessel's buoyancy and thereby improve the vessel's ability to return to the upright.

Buoyancy and the importance of beam

a. Vessels with a wide beam

In a vessel with a wide beam, the centre of buoyancy can travel further out sideways when the vessel rolls. This means a vessel with a wide beam is more stable at a small angle of heel as the centre of buoyancy can travel further sideways and is more effective at pushing the vessel back to the upright.

A vessel that rolls with a quick motion means the buoyancy is pushing back quickly against the roll. A vessel doing this is called stiff.

b. Vessels with a narrow beam

The opposite is true of narrow vessels, where the centre of buoyancy has a much more limited ability to travel sideways and there is a much-reduced ability to push back against the roll of the vessel. These vessels will have a much slower roll and are called tender, and are at far greater risk of capsize.

Diagram 8: The effect of vessel beam on the centre of buoyancy

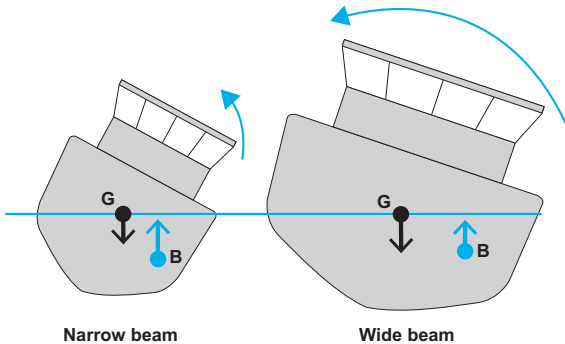

More information for skippers on how to identify if your vessel is stiff or tender can be found on page 29.

Buoyancy and the importance of freeboard

The vessel's freeboard is the distance from the water surface to the top edge of the deck.

As discussed on page 7, the more freeboard a vessel has, the greater its potential buoyancy.

a. Vessels with good freeboard

More freeboard creates more volume inside the vessel, which causes more water to be displaced, creating added buoyancy.

As a result, a vessel with good freeboard has good buoyancy at greater angles of heel. This is because in heeling over further, the increased freeboard allows the centre of buoyancy to travel further sideways, thereby returning the vessel to the upright more effectively.

So, the greater the freeboard your vessel has, the more stability it has at large angles of heel and the less likely it is to capsize.

b. Vessels with little freeboard

Vessels with little freeboard are at greater danger from the sea and unexpected waves, as they have less buoyancy and are less able to provide the necessary force to return the vessel to the upright.

Diagram 9: The effect of freeboard on buoyancy

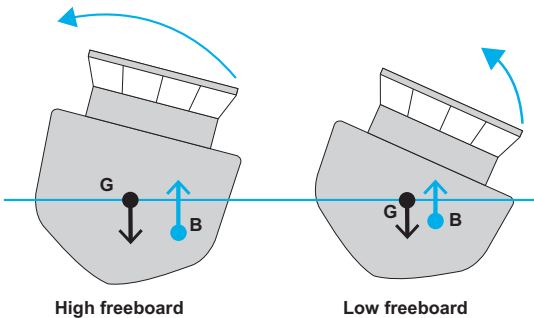

C. SUMMARISED RULES FOR GOOD STABILITY

For good stability make sure that your vessel has the following:

a. Low centre of gravity

A vessel with a low centre of gravity will more effectively pull the vessel back upright after heeling. The centre of buoyancy will then act more effectively to help push the vessel back upright.

A vessel with a high centre of gravity heels over further than one with a low centre of gravity. The further that a vessel with a high centre of gravity heels over, the less able it is to return to the upright. Therefore, it is more likely to capsize.

Further information for skippers on the importance of centre of gravity and how stability is assessed can be found on page 27.

b. Wide beam

Vessels with a wide beam allow greater sideways movement of the centre of buoyancy, which provides a greater counter to the forces heeling the vessel and improves stability.

c Good freeboard

The greater the vessel's freeboard, then the further over it can heel without capsizing.

You can improve a low freeboard in many ways, including the following two examples.

- i. A vessel with an aft wheelhouse could have a raised deck built along the wheelhouse. On other vessels, adding side buildings may raise the volume and buoyancy as a result.
- ii. Raising an entire deck is also an option, but this would also raise the weight of equipment as a result, so additional ballast would need to be considered to provide the same centre of gravity but a raised freeboard.

For information on Advanced Stability Concepts, please see the Skippers' Section of this booklet.

D. STABILITY HAZARDS AND RISKS

As explained earlier, it is important that you consider both the forces that act on the centre of gravity and the buoyancy, when you are either operating the vessel at sea, or are considering making changes to the vessel or its fishing method.

These forces can be considered as hazards to vessels. A hazard is an object or situation that can cause harm. The likelihood of that hazard occurring is the risk.

The following sections highlight how different hazards can affect the vessel's centre of gravity, its buoyancy and the ability of the vessel to return to the upright.

The section then explains how you can act to eliminate or minimise these hazards and reduce the risk of them happening.

a. What are the hazards and risks to stability and how can you minimise them?

i. External forces causing heel

Heel is when external forces push or pull the vessel from the upright. The hazard to the vessel is caused by the vessel heeling due to wind, towing, becoming snagged on obstructions on the sea bed or turning too quickly.

External forces will create a heeling moment which has two parts, the force and the distance.

If the force is acting high up, it will cause a greater heeling moment than if it is acting low down. The larger the heel, the greater the hazard.

Diagram 10: The effect of height on the angle of heel

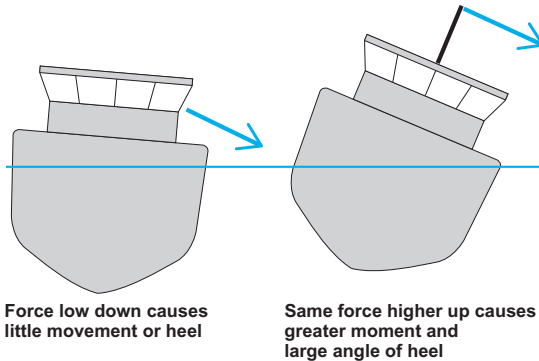

You can reduce the chances of capsizing happening from a large heel, and therefore the hazard and risk, by:

- keeping the towing warps and weight on the vessel low down
- having a wide beam
- having a high freeboard.

You can reduce the possible consequences by being able to remove the external forces (e.g. with a quick release mechanism on the winch, or by having bolt cutters, grinder or axe immediately available).

ii. Uneven weight distribution causing a list

Weight that is unevenly distributed away from a vessel's centre line causes the **hazard** of a list. A list is different to a heel in that a list will not correct itself unless the weight causing the list is moved.

As discussed on page 10, the position of the weight will affect the position of the centre of gravity. If you move a weight across the vessel, the centre of gravity moves across with it. The centre of buoyancy will then follow until it is underneath the centre of gravity, causing a list and creating the hazard.

Also, placing that weight higher up means the centre of gravity will be raised, resulting in the list being greater. Therefore, the further to the side you place a weight and the higher up you place it, the greater the list and, in turn, the greater the hazard will be.

When a listing vessel heels, the vessel's centre of buoyancy cannot travel as far sideways, so it is less able to return the vessel to the upright as a result. This increases the **risk** of capsize.

Diagram 11: Uneven distribution of weight may cause a list

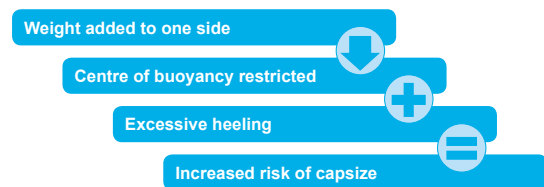

iii. Unexpected movement of weights

Unexpected sideways movement of weight on a vessel may cause it to list, reducing the ability to counteract any heel.

To remove the hazard and reduce the risk created by items moving, items on deck, such as equipment (e.g. booms, derricks, fishing gear and the catch itself) should be secured or contained to prevent any movement.

iv. Movement of liquids in tanks

Liquids cannot necessarily be contained, which means liquids on deck and in tanks can act to affect a vessel's stability.

If a tank is not full, it is called a slack tank. The liquid will therefore flow to one side when a vessel heels. As it moves, the liquid's weight will move the centre of gravity with it, creating the potential for capsize.

If this hazard combines with a high centre of gravity or poor buoyancy from a small beam or low freeboard, there is an increased risk of capsize.

The risk for potential capsize can be reduced by having longitudinal sub-divisions within tanks. The sub-divisions will reduce the movement of liquid, and therefore restrict the movement of water from one side to the other and reduce the movement of weight, leading to a lesser risk of capsize. More information on tanks is contained in the Skippers' Section.

Diagram 12: Reducing the risk caused by liquid in tanks

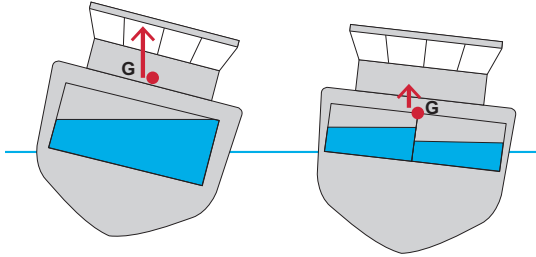

No sub-divisions in tanks cause greater free surface effect and weight movement increases

Sub-divisions reduce free surface effect and less weight movement

v. Free surface effect

If water gets into a vessel or cannot escape from the deck, this can cause free surface effect. The water will move from one side to the other and cause the vessel to heel and eventually capsize.

Water on deck will also raise the centre of gravity. In addition, it will reduce the freeboard and increase the chances of more water getting on deck, leading to a situation that may get out of control.

Fish, boxes and bags can also cause free surface effect, so fish must be in pounds, boxes or bags and the boxes and bags must be secured

Diagram 13: The effect of free surface water (or catch) on a vessel

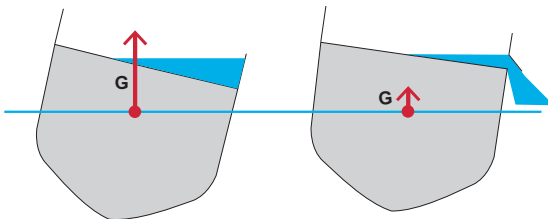

Water cannot escape, centred gravity will rise as will capsize risk

Water can escape, centre of gravity stays in position

Diagram 14: The effect of free surface water

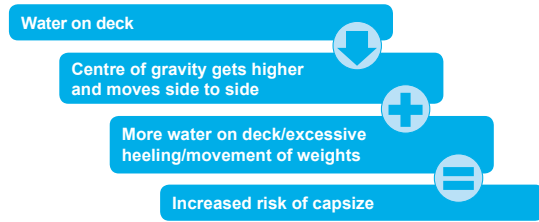

To prevent free surface effect, it is important to keep the water out of all enclosed spaces that prevent it draining away.

You need to keep the vessel watertight and weathertight.

- **Weathertight** structures must be able to prevent water entry in normal sea conditions.
- **Watertight** structures must be able to prevent the entry of water in all sea conditions and in all directions.

Openings above the freeboard deck can be weathertight.

Openings in or below the freeboard level must be watertight.

To ensure the vessel is watertight:

- pipes and valves must be in good condition, with shut offs
- the hull must be in good condition
- watertight doors, hatches and windows, and other closing devices must be maintained in good working order.

All watertight and weathertight closures should be kept closed at sea when not in use, even in good weather.

Vents and air intakes should be as high and near the centreline of the vessel as possible, to minimise the possibility of water getting in through them.

Freeing ports must not be closed or blocked in any way.

vi. Vertical movement of weight

As mentioned on page 10, the height of a weight affects the height of the centre of gravity.

Adding or loading weights will move the centre of gravity towards that load. The higher the weight, the more the centre of gravity will move upward towards it, potentially creating a hazard.

Remember that small weights high up have the same effect as a larger weight lower down.

The risk increases as you add more weight higher up or remove weight from low down.

Therefore, great care must be taken when adding or removing weights from a vessel, or when lifting or loading any weights, such as the catch.

Loading, lifting or adding weights low down is far safer than doing so from a high position.

Not all added weight may reduce stability. If you add weight above the centre of gravity, this will reduce stability. However, if you add weight, such as ballast, below the centre of gravity, this can improve your stability, as the centre of gravity will move lower down the vessel towards the added weight. However, always make sure you seek a consultant's advice when adding ballast, as well as making any other modifications to a vessel.

vii. Loll

If too much weight is added high up the vessel, then the centre of gravity will also be too high and cause the vessel to loll. This is different to a list. A list is caused by too much weight on one side, whereas a loll is caused by weight that is too high up.

When a vessel lolls, it is at much greater risk of capsize than from a list. Unlike a list, where the vessel remains on one side, in a loll the vessel can flop from one side to the other, often in a violent motion. If other external forces, such as movement of weight or a free surface effect, occur, then the risk of capsize is extremely high.

To correct a loll:

- lower weight within the vessel
- add weight low down – starting on the low side
- remove weight high up – starting on the high side
- reduce or remove any free surfaces if possible.

All these measures will reduce weight that is too high up the vessel and will correct a loll.

viii. Suspended loads

The weight of loadings being lifted is at the point of suspension, not at the point of the weight itself. This creates a hazard, as the centre of gravity can be affected by the height at which the weight is suspended.

A load that can swing is also a hazard.

Lifting operations using cranes, A frames, booms, derricks or gantries, can increase the chances of capsizing for two reasons:

- When the vessel heels, the suspended loads swing outwards in the direction of any heel and pulls the vessel even further over to that side, increasing the heel and the risk of capsizing.

If the buoyancy of the vessel cannot correct the heel, and other external forces add to the heel, or weights or liquids start to move to that side as well, then the vessel will capsize.

- The weight of a suspended load is at the point of suspension, not at the point of the weight itself.

The higher the weight, the higher the centre of gravity. So, the higher the point of suspension, the higher the centre of gravity and the greater the risk of capsizing. When the weight is out of the water, it is irrelevant whether the weight is just above the water or just below the point of suspension.

Remember that even a small weight high up is equivalent to a larger weight lower down and will cause a greater heel. If the vessel's buoyancy is not good, it can mean a greater risk of capsizing.

Diagram 15: The effect of suspended loads on a vessel heel when removed from the water

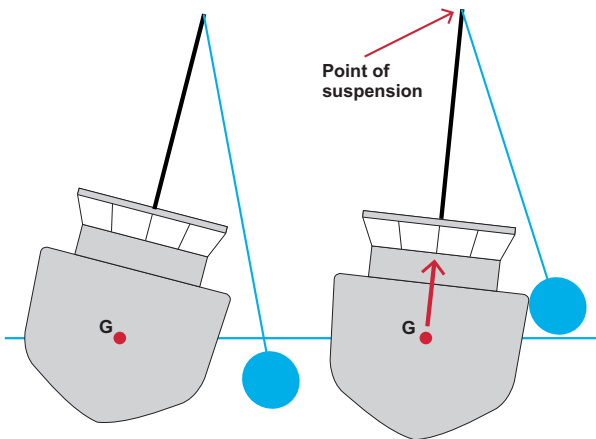

While the load is in water the centre of gravity remains unchanged

Once out of the water the centre of gravity moves towards the point of suspension. The higher this point, the greater the heel angle and capsizing risk

Diagram 16: The consequences of suspended loads

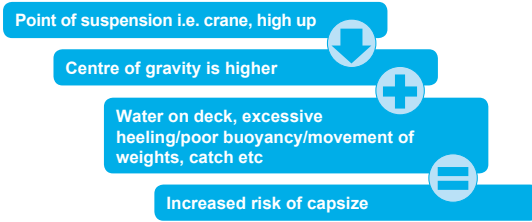

To minimise the risks when lifting and loading, keep the vessel's centre of gravity as low as possible by keeping weights and towing/suspension points low.

Diagram 17: Reducing the risks while lifting and loading

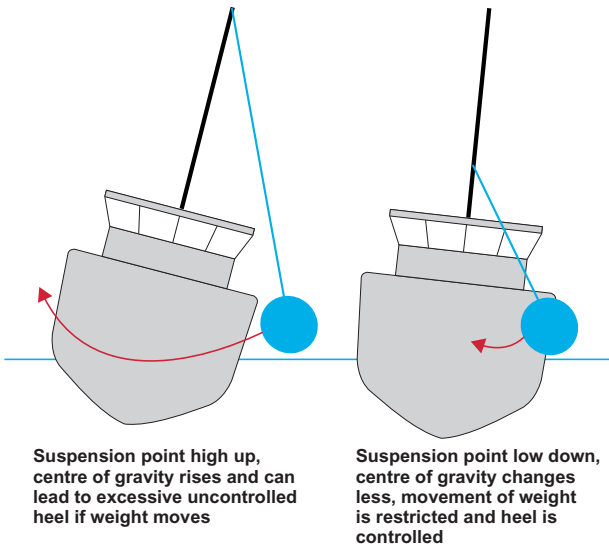

Look critically at the vessel and where you have positioned weights. This may identify some weight that can be repositioned lower, or perhaps removed from the vessel, (i.e. derricks or winches that are no longer used).

b. Preventing a chain of events

Many capsizes are caused not just by a single event, but by a number of events that react with each other. Often by removing the possible factors that can act in such a chain of events, capsizing can be prevented.

By doing the following you can remove the links in the chain and reduce the risk of capsizing:

- secure all equipment to stop it shifting across the deck
- make sure the catch is kept in pounds or boxes
- secure all openings into the vessel, such as doors and hatches
- keep freeing ports open
- keep weight as low as possible
- lift and load your vessel from a low point
- think about your freeboard, the higher the better
- keep pipes, valves and the hull in good condition
- use quick release systems on winches, or have bolt cutters, grinder or axe immediately available.

PART 2

SKIPPERS' SECTION

INTRODUCTION

In **Part 1** of this booklet, the concepts of centres of gravity and buoyancy were discussed.

In **Part 2** we look at the advanced stability concepts and the Wolfson Mark, which are covered in the Seafish Advanced Stability Course, and how these relate to the basic principles of stability discussed in the first section of the booklet. The remainder of this booklet is therefore aimed at skippers.

A. HOW STABILITY CHANGES AS THE VESSEL ROLLS

The horizontal distance between the line of downward force from the weight (acting downward from the centre of gravity) and the buoyancy force (acting upward from the centre of buoyancy) is known as GZ , or the righting lever.

Because buoyancy moves from side to side as the vessel heels, GZ will increase as the vessel heel increases, as shown in Diagram 18 below.

Diagram 18: The effect on GZ as the vessel heels beyond a certain point

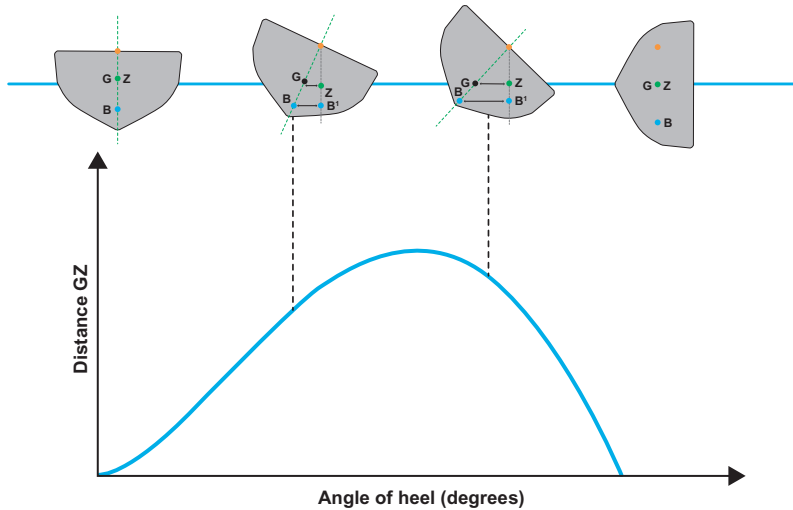

Diagram 19 overleaf shows the effect of a vessel as it heels over further and the relationship with the GZ distance.

As a vessel heels, GZ will increase as the gap between the line of downward weight force and the line of upward force of buoyancy increases.

If the vessel rolls too far, the centre of buoyancy cannot move any further and GZ starts to get smaller again, the vessel becomes top heavy and eventually capsizes.

However, it should be noted that as a vessel's heel increases beyond a certain point, then GZ will start to get smaller as the two lines of force start to get closer again.

This relationship between GZ and the angle of heel is known as the GZ curve and is shown in the diagram.

The point at which the angle of heel is such that the vessel will capsize therefore depends on the vessels beam, the hull shape, the height of decks above the waterline, and the amount and positioning of weights.

Diagram 19: The GZ curve

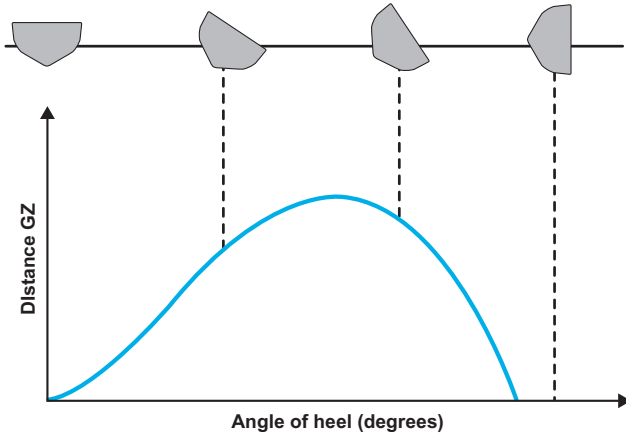

B. HOW CHANGING THE CENTRE OF GRAVITY CAN AFFECT THE VESSEL'S STABILITY

As the distance between the two lines of force, or GZ, will depend fundamentally on how far sideways the centre of buoyancy can travel and the height of the centre of gravity, the actions you take will affect these factors, and will influence when that angle of heel is reached.

As explained earlier, the height of the centre of gravity is important for the stability of the vessel. The height of the centre of gravity can be represented by the distance between the keel bottom (K) and the centre of gravity (G). This distance is known as KG.

As the height of the centre of gravity increases, so KG also increases.

Diagram 20 below shows how the distances between the keel and the centre of gravity for various KG distances might affect the GZ curve, and therefore the angle of heel at which the vessel will capsize.

Diagram 20: How changes to the centre of gravity can affect vessel stability

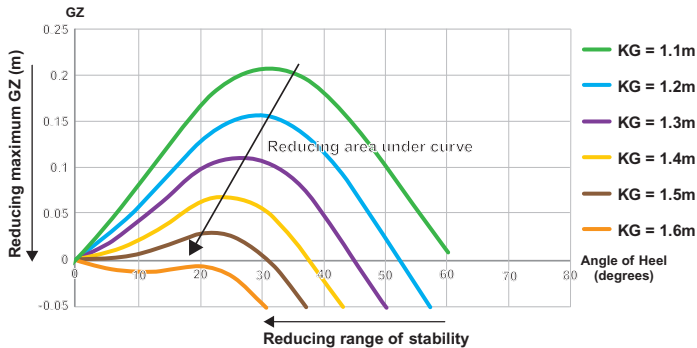

The green GZ curve is typical of a vessel that just meets the requirements.

As the graph shows, as KG increases, GZ (the distance between the two lines of upward and downward force) will become smaller at all angles of heel. A vessel with a high centre of gravity will become unstable at a much smaller angle of heel, than a vessel with a low centre of gravity. Just before it becomes unstable, the vessel will loll.

As Diagram 20 also shows, as the centre of gravity rises, so the GZ curve shrinks, and the risk of capsize increases.

In conclusion there are three impacts on stability:

- As the GZ curve gets smaller, there is an increasing risk that factors causing unexpected angles of heel, such as wind, waves fast, water on deck or heavy loads, will cause a capsize as the vessel does not have the ability to return to the upright
- If the area under the GZ curve reduces, it takes less force to capsize the vessel, so capsize is more likely
- A reducing range of stability means that the angle at which the vessel will capsize is smaller.

C. ROLL PERIODS

There are ways of checking where GZ is likely to be when the vessel heels. By observing the roll period of the vessel, you can monitor the stability of your vessel to ensure it is safe.

The roll period is the time taken to roll from one side, over to the opposite side, and back again.

It is more accurate to time five rolls and average this out when calculating the period for one roll.

Diagram 21: Observing roll periods

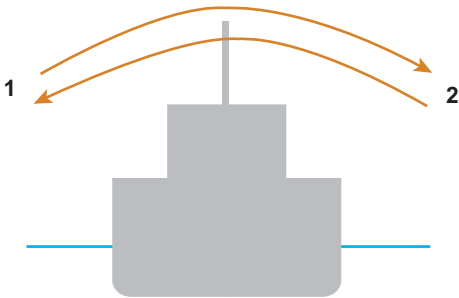

A stiff vessel has a roll period (in seconds) that is less than the beam of the vessel (in metres).

A tender vessel has a roll period (in seconds) that is more than the beam of the vessel (in metres), and indicates that the centre of gravity is too high.

Therefore, if the centre of gravity rises and the roll period increases, this indicates that the GZ of the vessel is also smaller, and the vessel is likely to capsize at smaller angles of heel.

A roll test can indicate whether the vessel is at risk of capsize. Examples of Roll and Heel Test forms are found at the end of this booklet.

D. THE WOLFSON MARK

A Wolfson Mark is used to ensure that sufficient freeboard is maintained for all operations.

It indicates how far the vessel can be heeled for any condition of loading, and for different sea states.

It is important to be familiar with the position of the Mark to identify when an operation is reducing freeboard too far.

Diagram 22: Monitoring freeboard

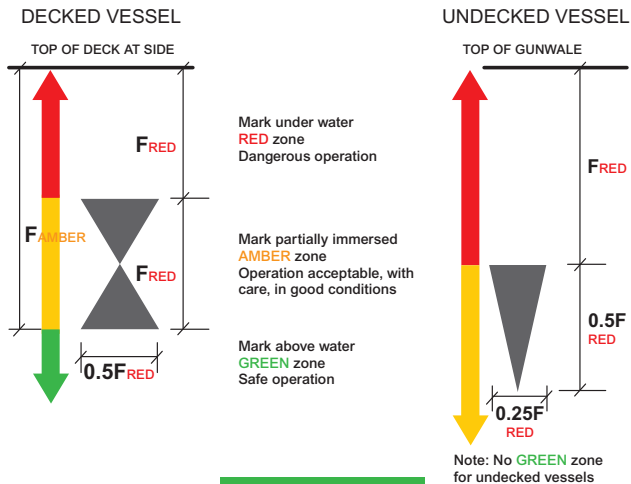

When the waterline is above the top of the mark, whether upright or when heeled during lifting operations, the vessel is in danger of capsizing.

When the waterline is below the TOP of the mark, whether upright or when heeled during lifting operations, the vessel has a low safety level against capsizing or swamping in a seaway.

Undecked vessels do not have a “safe” zone because of their constant vulnerability to swamping.

Diagram 23: Safe lifting loads

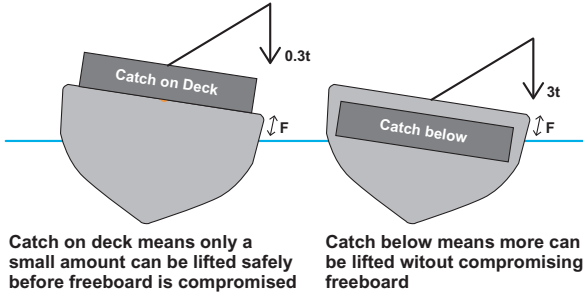

A dangerous loss of freeboard (F in diagram 23 above) can occur with different crane loads, depending on the loading condition of the vessel.

- The vessel in the left diagram has reduced stability due to the catch being on deck. When the Wolfson Mark is just immersed only 0.3 tonnes can be lifted safely.
- The vessel in the right diagram has increased stability due to the catch being in the hold. When the Wolfson Mark is just immersed the safe lift is now 3 tonnes.

Note also that if the vessel is heavily loaded, the mark will be immersed at a smaller angle of heel than when the vessel is lightly loaded.

You should ensure the crew are aware of the Wolfson Mark, and the following points:

- The Wolfson Mark indicates the minimum freeboard necessary.
- In calm conditions the Mark can be partially immersed.
- The Mark should **never** be completely underwater.

Remember, it is not the heel angle that indicates the level of risk, but the remaining freeboard when the vessel is heeled.

E. TANKS

The free surface effect of a tank depends on its size, shape and orientation in the vessel.

a. Depth

Tank depth has no influence on the free surface effect.

Diagram 24: The free surface effect

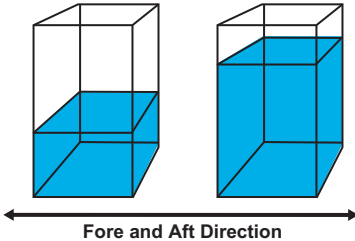

Both tanks in Diagram 24 have the same free surface effect.

However, the fuller tank is heavier, so will move the centre of gravity more than the emptier tank. This effect is helpful if the tank is low down, but harmful if the tank is high up.

The effect of the weight of the liquid is NOT the free surface effect. The free surface effect is due to the shape of the **surface** of the liquid, and always reduces stability.

So, in these two tanks, where the shape and size of the free surface is the same, the free surface effect is the same.

b. Length – in fore and aft directions

Tank length is directly proportional to the free surface effect.

Diagram 25: Tank length and the free surface effect

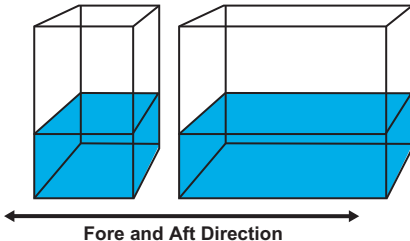

So, a tank of twice the length has **double** the free surface effect.

However, this is not the case if the tank is positioned across the breadth of the vessel.

c. Breadth – across the vessel

Tank breadth has a greater impact on free surface effect.

The impact is proportional to the breadth squared, so a tank of twice the breadth has **four times** the free surface effect.

Diagram 28: Tank breadth and the free surface effect

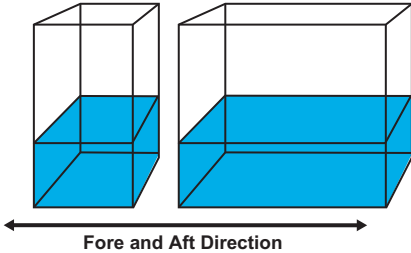

d. Free Surface Effect

When planning to install tanks, you should aim for them to reduce the likely free surface effect. This can be done by:

- using two or more small tanks rather than one big tank
- positioning tanks, so that the longest side is fore and aft, and the shortest side is across the vessel
- using tanks that are made with internal sub-divisions that are positioned in the fore and aft direction.

F. MODIFICATIONS

Whenever you make a modification to your vessel, remember that you could affect the vessel's centre of gravity and therefore its stability.

Examples of changes that could affect your stability include, but are not limited to:

- bigger winches or net drums
- changing the position of winches and net drums
- shelter decks
- taller lifting gantries
- bigger cranes
- fish hoppers
- replacing an old engine with a lighter weight engine.

These modifications will often result in moving the centre of gravity upward, whether it's from adding weight above the centre of gravity or reducing the weight below it.

The higher the weight is added, the greater the movement of the centre of gravity.

When making modifications to the vessel you should always seek the advice of a consultant and then ensure that you inform the MCA to seek approval.

ANNEX A

FV Roll Test Form

Vessel Beam @ deck (m) =

Mark on side (m) above waterline = Beam in metres / 8 =

First 5 rolls (secs) =

Second 5 rolls (secs) =

Third 5 rolls (secs) =

Total time in secs for 15 rolls =/15 =

Time for one average roll (secs)

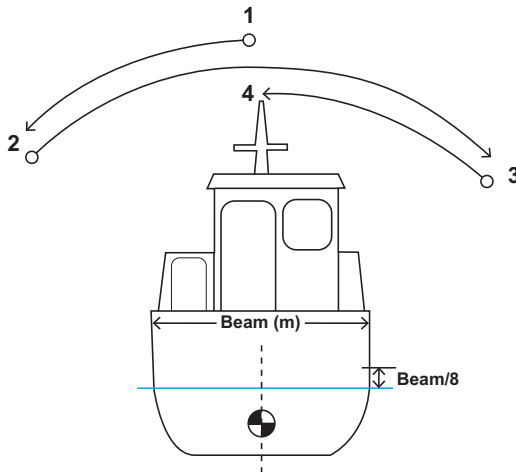

Time for one complete roll is as per the above diagram, starting at position 1 through to position 4. Alternatively, you can start from another point if preferred.

If the average roll period in seconds is longer than the beam in metres, then you must contact your local MCA surveyor or Seafish Services for free advice and assistance. The MCA or Seafish Services may direct you to a qualified Naval Architect if necessary, or you could contact them directly in the first instance.

FV Heel Test Form

Vessel Loading Condition

Fish hold empty

No ice Fuel tanks full

Deck cargo secure

Weight used for test (remember this should be repeatable with the same weight)

.....

.....

Date: Angle:

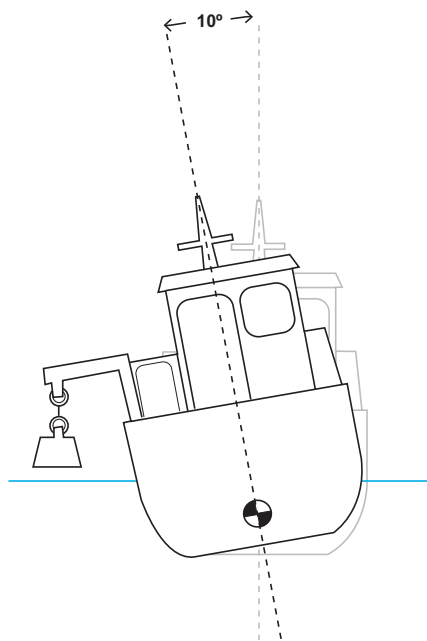

Repeat Tests

The repeat tests should be no more than 10% different to the original test above.

If the percentage of change is greater, seek professional advice.

Date: Angle:

Date: Angle:

Date: Angle:

Vessel Standards
Maritime & Coastguard Agency
Email: fishing@mcga.gov.uk
Tel: 0203 817 2000
www.gov.uk/mca

Issued March 2018
MCA/263